

# COUNCIL COMMISSIONER MANUAL



BOY SCOUTS OF AMERICA®

# **Council Commissioner Manual**

October 2010



# TABLE OF CONTENTS

	Page
<b>PREFACE</b> .....	<b>5</b>
<b>SECTION I The Council Commissioner</b> .....	<b>7</b>
Chapter 1 “Fast Start” for Council Commissioners .....	9
Chapter 2 A Brief History of Commissioners.....	9
Chapter 3 Commissioner Basics.....	10
Chapter 4 The BSA Organizational Structure as Related to the Council Commissioner (Charts A, B, and C).....	11
Chapter 5 Core Purposes of the Council Commissioner (Chart D).....	15
Chapter 6 The Council Commissioner’s Significant Working Relationships.....	17
Chapter 7 The Council Commissioner and the Council Commissioner Team .....	17
Chapter 8 The Council Commissioner’s Goals for the Council’s Unit Commissioners.....	21
Chapter 9 Overall Points of Importance for Council Commissioners .....	22
Chapter 10 The Role of the Council President in Relationship to the Council Commissioner .....	22
Chapter 11 The Relationship of the Council President to the Scouting Professional Staff .....	23
Chapter 12 The Role of the Council Scout Executive in Relation to the Council Commissioner.....	23
Chapter 13 The Council Commissioner’s Responsibilities as a Council Executive Board Member .....	24
Chapter 14 The Role of the Council Commissioner and the Board in Program/Quality.....	25
Chapter 15 The Council Commissioner’s Vision Statement .....	26
Chapter 16 Ensure High-Quality Commissioner Service From Administrative Commissioner Team Members .....	27
Chapter 17 Assistant Council Commissioners .....	27
Chapter 18 Meetings .....	28
Chapter 19 The Commissioner Annual Service Plan for Units .....	29
Chapter 20 The Council Commissioner’s Annual Conference and the College of Commissioner Science.....	29
Chapter 21 Required and Suggested Council Commissioner Training and Awards .....	30
Chapter 22 A Checklist of Characteristics of a Council Commissioner.....	31

<b>SECTION II</b>	<b>The District Commissioner and Assistant District Commissioner .....</b>	<b>33</b>
Chapter 23	The District (Chart E) .....	35
Chapter 24	The District’s Purpose .....	37
Chapter 25	The District’s Relationship to the Council .....	37
Chapter 26	The Four Functions of the District .....	37
Chapter 27	The Duties of the District Commissioner .....	38
Chapter 28	The Roles of the District Commissioner .....	39
Chapter 29	The Responsibilities of the District Commissioner .....	39
Chapter 30	The District Commissioner Team .....	41
Chapter 31	How Large Is a District Commissioner Team? .....	41
Chapter 32	The Test of an Effective District Commissioner Team .....	41
Chapter 33	How to Be Successful as an Assistant District Commissioner .....	42
Chapter 34	The Role of the District Executive (Professional Scouting Staff) .....	43
<b>SECTION III</b>	<b>The Unit Commissioner .....</b>	<b>45</b>
Chapter 35	The Role of Unit Commissioners .....	47
Chapter 36	The Unit Commissioner’s Service Function From the Unit Leader’s Perspective .....	47
Chapter 37	The Nature of Commissioner Unit Service .....	48
<b>SECTION IV</b>	<b>National, Regional, and Area Support Council Commissioners .....</b>	<b>49</b>
Chapter 38	National, Regional, and Area Support Council Commissioners .....	51
Chapter 39	National Commissioner .....	51
Chapter 40	Regional Commissioner .....	52
Chapter 41	Area Commissioner .....	53
Chapter 42	National Commissioner Support Team .....	54
<b>SECTION V</b>	<b>Background Information .....</b>	<b>55</b>
Chapter 43	A Detailed History of Commissioner Service in Scouting .....	57
Chapter 44	Voluntarism and Commissioners .....	59
Chapter 45	Movements Versus Organizations .....	59
Chapter 46	Resources .....	60
Chapter 47	BSA Rules and Regulations .....	62

## **PREFACE**

*Why do we need a Council Commissioner Manual?*

In the summer of 2009, the new National Council Commissioner Service Support Team became aware that there was no formal training material for the all-important job of council commissioner. This was rather amazing, because at that point Boy Scouting was 99 years old. One team member undertook the task to compile and write this manual, utilizing input from council commissioners around the country. This was a major collaborative effort of both council volunteers and professionals.

Much of the information in this manual was secured from other BSA published materials, gathered from Scouters in councils around the country, or pulled from national BSA presentations at annual meetings, Philmont, or Colleges of Commissioner Science.

This manual was compiled and written from the point of view that it would be a basic, yet comprehensive, guide for someone who has never been a council commissioner. It is meant to orient someone who does not have many years of Scouter experience at the council level and who is not familiar with council operations. This person might be a community leader who is willing to serve in this high-level council position, or someone who has many years of adult Scouter experience and an extensive list of Scouting positions, such as unit leader, unit commissioner, or Scouting volunteer.

For others, it was intended to be a comprehensive manual, covering all subjects one might need to know to perform the task, but not to be an exhaustive collection of information. That is, it was not intended to discuss every subtlety, nuance, and observation that could be made regarding almost every section and statement in the manual related to the council commissioner role.

An observation noted when compiling this material was that there is great variation from council to council about the role of the council commissioner. This manual was written to allow for those variations, and should be read in that way. Not everyone will agree with everything in the manual, because there isn't agreement about the role of the council commissioner and what they do in Scouting. This is the single, most important thing learned from writing the manual—that it should be seen as the beginning of some uniformity and agreement to the council commissioner role. The manual is really more of an outline that, if people begin to follow, Scouting will have better council commissioners over time.

All these efforts were undertaken with the hope that this will bring together everything that council commissioners and their administrative teams need to get started when they agree to undertake the all-important task of council commissioner, district commissioner, and their assistants.

We would especially like to thank Tico Perez, our national commissioner; “Wisconsin” Bob Coons, National Commissioner Service training chair; our National Commissioner Service Team, and those others who helped make this manual possible.



# **The Council Commissioner**



## CHAPTER 1. “FAST START” FOR COUNCIL COMMISSIONERS

### The Council Commissioner

- **Is a:**
  - Leader of all the council’s commissioners
  - Representative of all the uniformed youth and Scouters
  - Member of the council:
    - Key 3
    - Executive committee
    - Executive board
  - Liaison between professional staff and volunteers
  - Chief morale officer of commissioners—raising their profile and impact throughout the council
- **Ensures:**
  - Recruiting an adequate number of unit and administrative commissioners
  - Orientation of all new commissioners
  - Training unit and administrative commissioners
  - Implementing all functions of unit and administrative commissioners
  - Reporting progress toward the goals of all commissioner functions
  - Evaluating the functioning of the commissioner team and making changes when necessary
  - Formulating succession plans for the administrative commissioner team
- **Oversees, through the unit commissioners:**
  - Monthly unit visits and contacts
  - Support services to unit leaders
  - Delivery of a quality Scouting program to all youth

## CHAPTER 2. A BRIEF HISTORY OF COMMISSIONERS

When Scouting first started in 1910 in America, it was understaffed. There were no Scouting professionals outside the national office. Volunteers, then known as commissioners, helped start, register, and service units as they were formed around the country. As Scouting grew and professional staff was hired, volunteer commissioners continued in this role of assisting and servicing units.

To this day, the function of volunteer unit commissioners is to do whatever it takes to help units succeed, and thus be able to deliver the Scouting program to the youth of America.

A more detailed history can be found in Chapter 43 on page 57.

## **CHAPTER 3. COMMISSIONER BASICS**

All commissioners should be familiar with the basic tenets of the Boy Scouts of America and their local council. These include:

- BSA Mission Statement
- BSA Vision Statement
- The Purpose of the Boy Scouts of America
- Scout Oath
- Scout Law
- Your council's mission statement, vision statement, and strategic plan

### **BSA Mission Statement**

The mission of the BSA is to prepare young people to make ethical and moral choices over their lifetimes by instilling in them the values of the Scout Oath and Scout Law.

### **BSA Vision Statement**

The Boy Scouts of America is the nation's foremost youth program of character development and values-based leadership training.

In the future, Scouting will continue to:

- Offer young people responsible fun and adventure;
- Instill in young people lifetime values and develop in them ethical character as expressed in the Scout Oath and Scout Law;
- Train young people in citizenship, service, and leadership;
- Serve America's communities and families with its quality, values-based program.

### **The Purpose of the Boy Scouts of America**

The charter of the Boy Scouts of America states that "the **purposes** of this corporation shall be to promote, through organization and cooperation with other agencies, the ability of boys to do things for themselves and others, to train them in Scoutcraft, and to teach them patriotism, courage, self-reliance, and kindred virtues, using methods which are now in common use by Boy Scouts."

### **Scout Oath**

On my honor, I will do my best to do my duty to God and my country and to help other people at all times, to keep myself physically strong, mentally awake, and morally straight.

### **Scout Law**

A Scout is:

- Trustworthy
- Loyal
- Helpful
- Friendly
- Courteous
- Kind
- Obedient
- Cheerful
- Thrifty
- Brave
- Clean
- Reverent

## **CHAPTER 4. THE BSA ORGANIZATIONAL STRUCTURE AS RELATED TO THE COUNCIL COMMISSIONER**

Who is the council commissioner?

Each local Boy Scouts of America council has a council commissioner. This person is a part of the council Key 3 (see Chart B on page 13), which consists of:

- The Scout executive,
- The council president, and
- The council commissioner.
- The Scout executive and council president may be asked for their input on potential council commissioner candidates. The council commissioner is an elected officer, and is therefore nominated by the council nominating committee and approved by the executive board (see the Council Nominating Committee Worksheet, No. 513-331).
- The council commissioner may also, at times, be asked for input on potential district commissioner candidates, or even offer input where strengthening of district leadership would be helpful, but should work through the district nominating committee process and obtain executive board approval (see the District Nominating Committee Worksheet, No. 513-332).

The council commissioner's primary functions are to:

- Represent all uniformed youth and Scouters,
- Represent all of the council's unit-serving commissioner's team in council matters,
- Achieve the goals of the council commissioner's team, and
- Raise the profile and impact of the commissioners at the council Key 3 and council executive board levels, and throughout the council.

The following three charts show the relationship of the council commissioner to the Scouting organizational structure:

- **Chart A** shows the council commissioner's role within the local council.
- **Chart B** shows the relationship of the council commissioner to the council Key 3, the council executive board and the council executive committee.
- **Chart C** shows the relationship of the council commissioner to the national commissioner structure.

Note: As the above three charts are reviewed, keep in mind that the purpose of the council is to establish, guide, and support districts for the achievement of the movement's purpose. Councils establish policies and programs, and districts carry out the policies and the mission in their respective territories.

The following chart shows the council commissioner's role within the council.

### COUNCIL COMMISSIONER ORGANIZATIONAL CHART

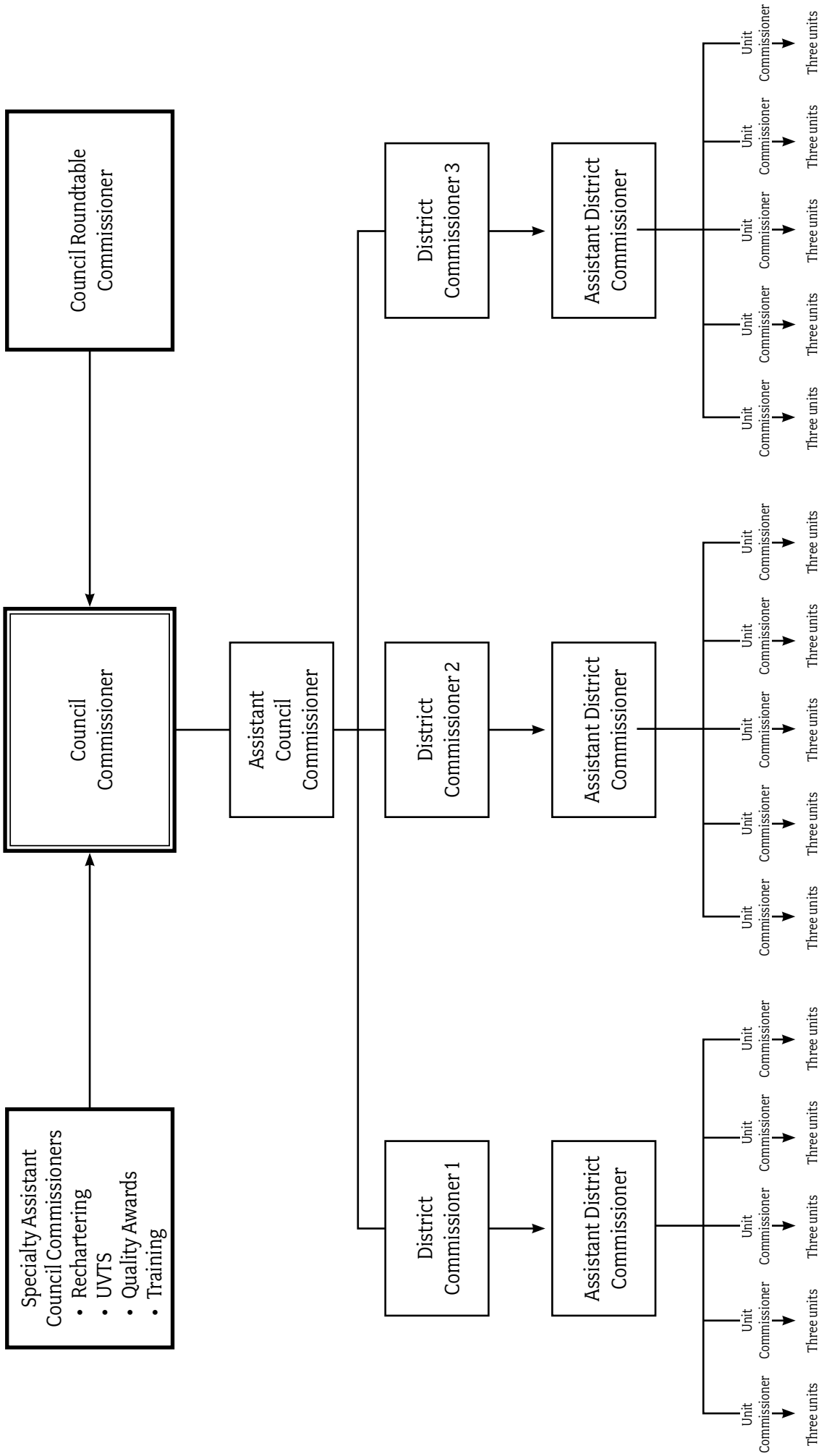
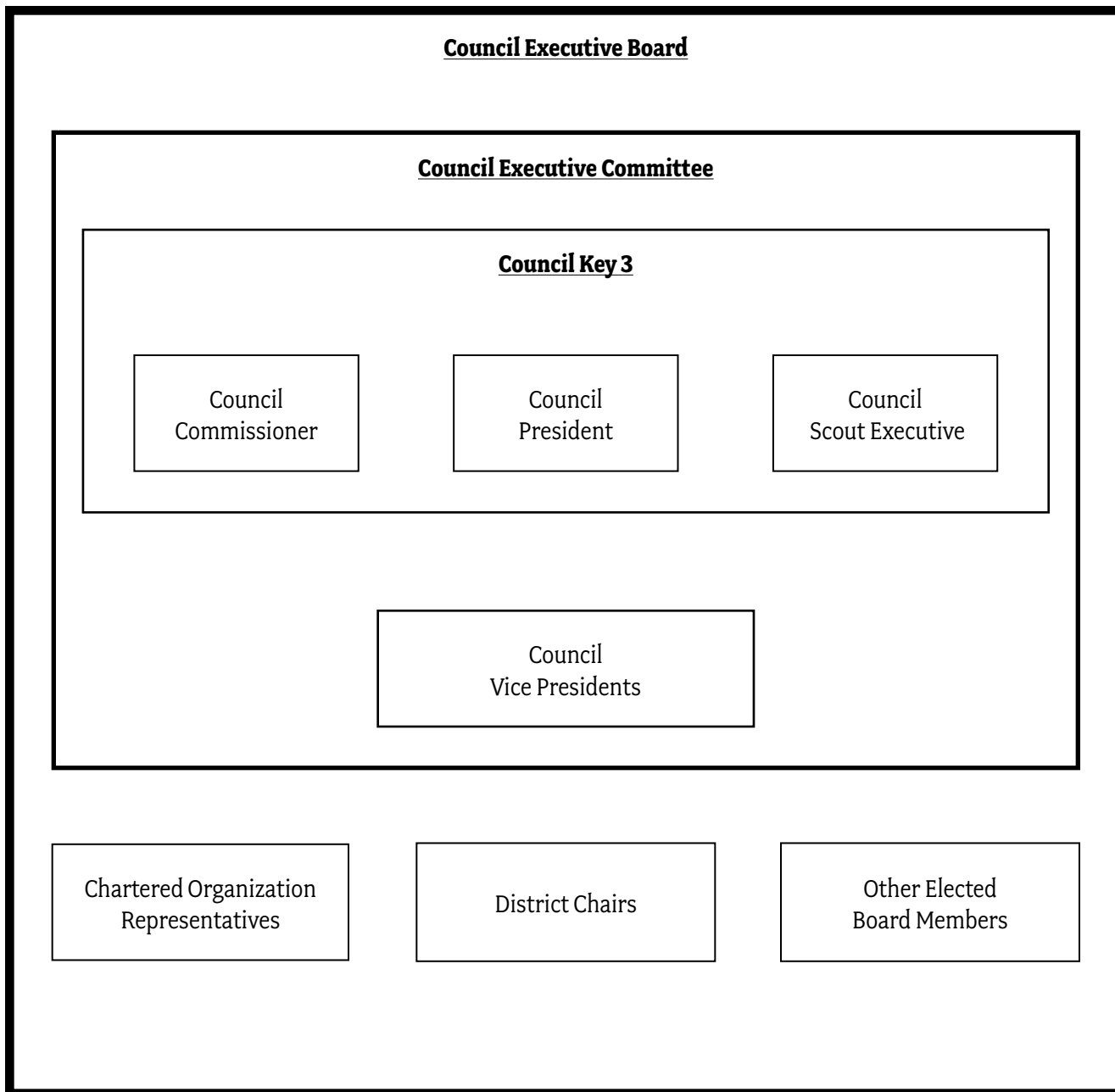

CHART B

The following chart shows the relationship of the council commissioner to the council Key 3, the council executive committee, and the council executive board.



The following chart shows the relationship of the council commissioner to the national commissioner structure.

**NATIONAL COMMISSIONER ORGANIZATIONAL CHART**

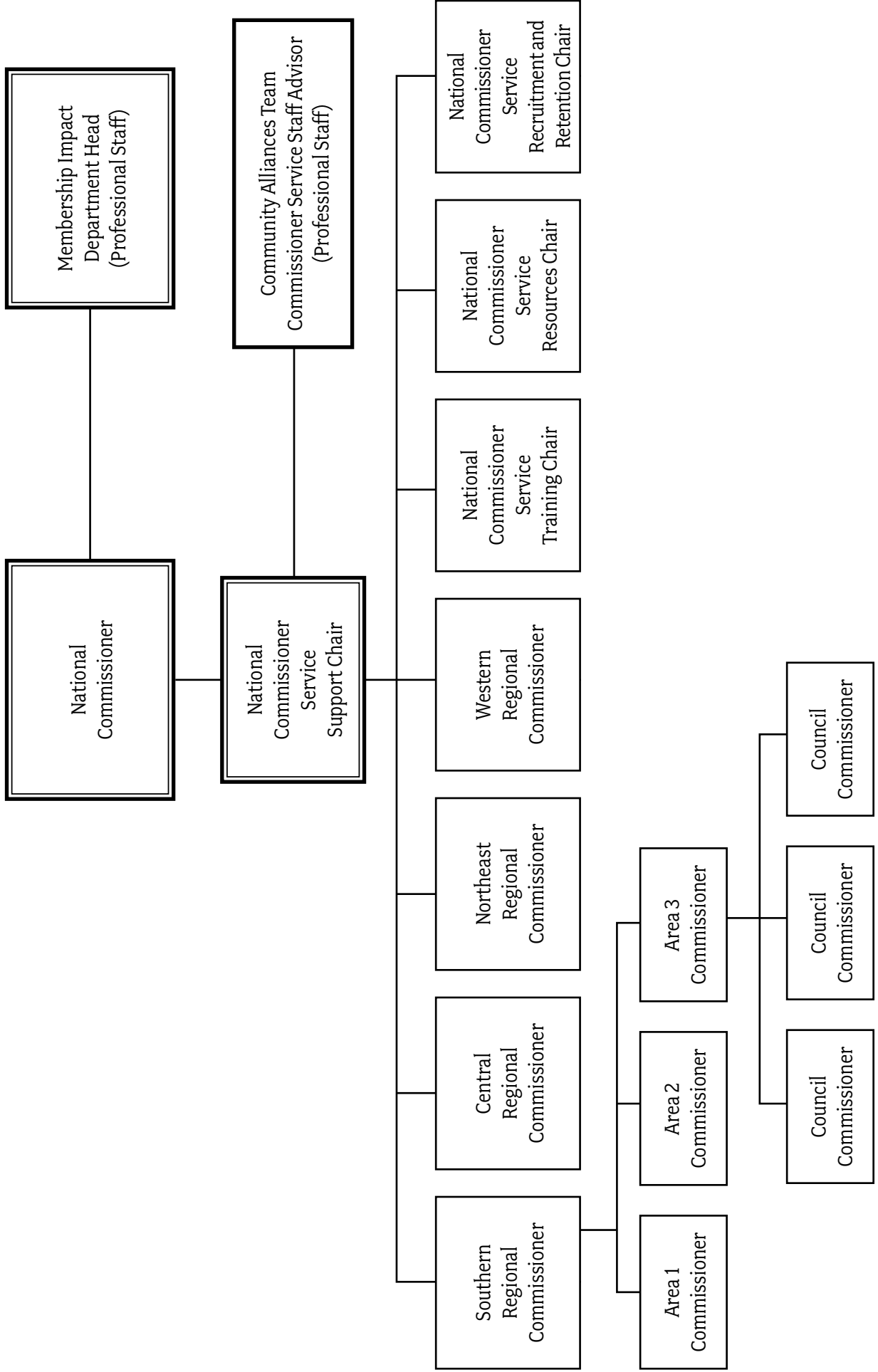

## **CHAPTER 5. CORE PURPOSES OF THE COUNCIL COMMISSIONER**

1. The council commissioner is responsible for each council unit—Cub Scout pack, Boy Scout troop, or Venturing crew—to be visited by a unit commissioner and receive commissioner service every month.

The purpose of these visits is for the unit commissioner to assist the unit leaders in their all-important goal of delivering the Boy Scouting program to the Scouts. The unit commissioner acts as a counselor, adviser, mentor, service representative, doctor, etc., when unit leaders need any type of assistance.

Without regular visits and contacts, unit leaders would have no direct contact with the Scouting structure other than district or council roundtables and the district executive. They would be on their own to implement the Scouting program without the training, skills, knowledge, assistance, and support that a commissioner can provide. This would make their role much more difficult, and their chance of success would be much lower. The unit commissioner is there to help units succeed in delivering the Scouting program.

Assisting units to successfully deliver a quality Scouting program is the core purpose of the councils' commissioners, and thus, it is also the core purpose of the council commissioner.

The other core purposes of the council commissioner are to:

2. Serve as officer of the local council, a member of its executive board and executive committee, and as a National Council member representing the local council.
3. Keep the president and executive board informed of the councils units' conditions and successes, and any problems in delivering the Scouting program.
4. Serve on the council Key 3 (see Chart D on the following page).

## CHART D

What is the Key 3 concept in Scouting and where do commissioners fit?

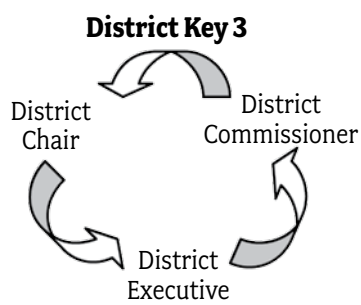
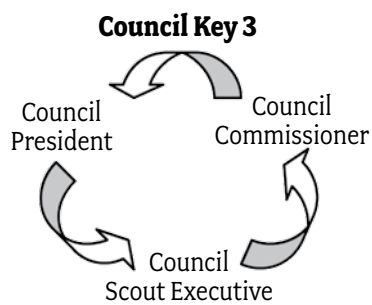
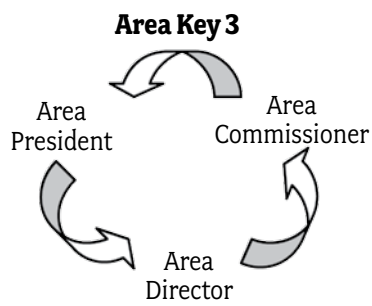
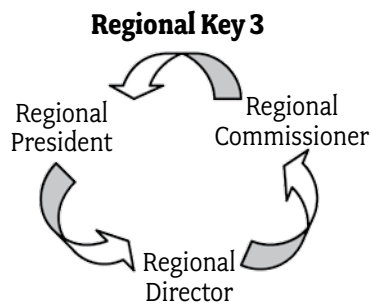

## **CHAPTER 6. THE COUNCIL COMMISSIONER'S SIGNIFICANT WORKING RELATIONSHIPS**

It is a basic premise of the Scouting program that Scouting is led by volunteers and guided by professionals. The commissioner role, while filled by a volunteer, is in many ways the point of contact between these two groups. It is the commissioner that acts as a liaison between professional staff and volunteers at the unit, district, and council levels. It's necessary for the council commissioner to work on promoting positive working relationships between the multitude of volunteers in each council and the staff of paid Scouting professionals. In this way, the council commissioner helps everyone accomplish their specific tasks for the betterment of Scouting.

The council commissioner, as part of the council Key 3, works together with the council president and the Scout executive at the council level. The council commissioner also works directly with many other members of the professional Scouting staff when appropriate—the director of field service, district executives, etc. It's important that the council commissioner develops and keeps positive working relationships with these professionals in order to assist them in their duties. The relationship is mutually beneficial in that they assist the council commissioner in fulfilling their goals, duties, and responsibilities—and their assistance is invaluable.

The council commissioner also works directly with the council president, who is the presiding officer of the council executive board and the council executive committee.

The council commissioner, again in the important role as a council Key 3 member, is a member of both of these key groups—the council executive board and the council executive committee. These two groups set directions and policies for the council, set the strategic plan and goals for the council, manage the council's finances, oversee the Scout executive's administrative actions, and are responsible for the quality of the Scouting program being implemented in each district.

The council commissioner is an important and integral part of all these top council functions (refer to Chart B on page 13).

## **CHAPTER 7. THE COUNCIL COMMISSIONER AND THE COUNCIL COMMISSIONER TEAM**

The council commissioner is the leader of the council's commissioner team, and must take a dynamic role in initiating and implementing all of the council commissioner functions and making sure that the council commissioner team's goals are met. The council commissioner is the inspirational leader of the council's commissioner team and promotes the quality of the Scouting program within the units.

The council commissioner's primary responsibility is to establish and operate a council administrative commissioner team. In order to do this, the council commissioner must, as a first and foremost function, recruit and train adequate numbers of quality volunteers to fill all of the council's administrative and unit-service-providing commissioner functions. These volunteers will help the council commissioner by organizing the administrative commissioner structure of the council and by being assistant council commissioners, district commissioners, assistant district commissioners, or unit commissioners. This entire administrative commissioner structure is there to provide support to the unit commissioners, who visit the units and perform the actual function of commissioners.

It is the council commissioner's primary duty to organize, recruit, nominate or appoint, and operate the council commissioner's administrative commissioner team in order to provide service to units. The positions are:

- Assistant council commissioners
- Specialty assistant council commissioners

- District commissioners
- Assistant district commissioners
- Unit commissioners (refer to Chart A on page 12)

The council commissioner's relationships with and responsibilities to the administrative team are:

1. Specialty Commissioners

Council commissioners over time have found that certain administrative functions can sometimes best be accomplished if the council commissioner recruits and trains specialty commissioners. Depending upon a council's size and preference, some of these could be:

- Council rechartering commissioner
- Unit Visit Tracking System commissioner
- Quality Award commissioner
- Council Webmaster commissioner
- Summer camp commissioners, etc.

2. Hold Commissioner Meetings

To organize this administrative function, the council commissioner must hold regular council administrative meetings with these individuals to check on their progress, set an agenda, set goals, and achieve these goals as per the council's strategic plan.

3. Recruit and Train

Another major administrative responsibility of the council commissioner is to be actively involved in recruiting and training administrative commissioners to work with them in conjunction with the Scout executive. Note: A number of these administrative positions, such as district commissioner, must be nominated by the district nominating committee in order to enjoy their support and involvement. They are then approved by the council executive board.

4. Evaluate Functioning

As the top administrative commissioner, it's necessary for the council commissioner to evaluate the functions of the commissioners in the administrative positions and make changes over time as necessary.

5. Annual Commissioner Conference

The council commissioner should plan and conduct a College of Commissioner Science or an annual commissioner conference for training, updates, planning, recognition, and morale building.

6. Succession Planning

The council commissioner should develop a succession plan in terms of grooming and training the next council commissioner and potential council commissioner administrative team members to take over the various positions as current terms are fulfilled. The council commissioner should do this in conjunction with the Scout executive.

The council commissioner's relationships with and responsibilities to unit commissioners are:

1. Recruit

First and foremost, the council commissioner is responsible for the administrative structure that recruits a sufficient number of unit commissioners so there is one commissioner for every three units

in the council. This has been the national standard for many years, and time has shown that attending to the needs of three units at a maximum gives unit commissioners the time they need to do a good job in providing service to these units. Unit commissioners can be recruited from:

- Unit leaders who have “retired” from their unit leader positions
- Involved parents of Cubs, Scouts, and Venturers who have gone through the Scouting program
- Former Scouts
- Eagle Scouts
- National Youth Leadership Training Programs
- Vocations that attract and develop mentors, e.g., college professors
- Philmont rangers
- Church officers
- Service organizations, e.g., Rotary, Lions, etc.
- Veterans organizations

## 2. Organize a District Commissioner Structure

While making sure each district secures enough unit commissioners to service the district’s units, the council commissioner must also make sure all of the council’s districts are organized with their own administrative commissioner structures:

- District commissioners
- Assistant district commissioners
- Specialty commissioners, if needed
- Unit commissioners

The district commissioner should hold regular meetings. These meetings should be at unique times and not combined with other district functions so attention can be paid to the important function of commissioning.

## 3. Training

The council commissioner must make sure there is regular and continuing education for all commissioners. New recruits should be put through Fast Start Commissioner Training and Unit Commissioner Basic Training. The council and district should provide regular ongoing training to all commissioners. Increasingly, councils have been encouraged to start a College of Commissioner Science, which tends to be periodic, all-day training sessions with different classes on commissioning subjects. All commissioners are encouraged to attend for several years and earn their bachelor’s, master’s, and doctoral degrees in commissioner science.

The council commissioner should evaluate the council’s commissioner training program and make improvements or additions when necessary.

## 4. Roundtables

Roundtables serve an educational function for the council’s commissioners and unit leaders, as well as an opportunity for them to meet outside of unit meetings, to get to know each other and to exchange conversation that will help the unit commissioners fulfill their functions. Roundtables are usually the responsibility of the district and the district commissioner, and are conducted by roundtable commissioners.

## 5. Volunteer Recognition

The council commissioner should also make sure all commissioners are recognized for their efforts in Scouting by doing the following:

1. Recognize commissioners for attending training.
2. Distribute commissioner awards (Chapter 21, page 30).
3. Give regular thank-yous.
4. Recognize commissioners for special achievements or longevity of service at council or district recognition events.

## 6. Leadership

Overall, the council commissioner must act as the champion or spirit of the council commissioner staff. This is the person who should be visible at council meetings and functions, who always has something positive and encouraging to say about commissioning, is enthusiastic about advancing the purpose of commissioners, and basically functions as the cheerleader or chief morale officer for the council's commissioners.

## 7. Camp Promotion/Outdoor Activities

The council commissioner should strongly encourage all packs, troops, and crews to participate in council camping opportunities. By working with their commissioner team, they can help increase attendance at national high-adventure camps and events and utilization of the council's facilities year-round. They should also encourage commissioners to attend training at the Philmont Training Center.

They may want to pay special attention to the council's health and safety concerns regarding camping and outdoor activities at council camps.

Council commissioners can promote camping scholarships for Scouting members with financial needs.

## 8. Activities and Civic Service

The council commissioners should promote various district activities, events, and civic service projects. This will help Scouting become more visible in the community.

## 9. Advancement

The council commissioner has a major role in advancement, a key part of the Scouting program. Advancement through the various ranks and awards for Cub Scouts, Boy Scouts, and Venturers is a key component to helping Scouting achieve its goals of developing character and leadership in youth.

Commissioners can assist with major advancement tasks such as:

- Helping unit leaders establish and maintain proper advancement procedures
- Monitoring a unit's advancements
- Participating in or conducting troop or district-level Eagle Scout boards of review
- Providing resources for advancement that are difficult for units to secure

## **CHAPTER 8. THE COUNCIL COMMISSIONER'S GOALS FOR THE COUNCIL'S UNIT COMMISSIONERS**

The council commissioner is ultimately responsible for all of the council's unit commissioners accomplishing these responsibilities. The council commissioner should work with the district commissioners, who work directly with their teams and the unit commissioners to achieve these goals:

1. To visit or contact each of their three units every month.  
  
The visits or contacts can be in person during a Cub Scout pack, Boy Scout troop, or Venturing crew meeting; a person-to-person meeting with the adult leaders of the units outside the unit's regular meeting time; a phone call or e-mail to the unit leaders; or a meeting with the unit's committee of adult leaders. The unit commissioner can also meet with the representative from the church, service club, or other organization that hosts the unit. The council and district should use the Unit Visit Tracking System (UVTS) so unit commissioners are held accountable for making the visits, documenting them, and reporting them to the administrative structure of the council.
2. To be responsible for the annual rechartering of each unit on time. The unit commissioner should be using the Internet-based online rechartering system to help with this all-important function.
3. To work with each unit to achieve the annual Quality Unit Award.
4. To follow and achieve the monthly Commissioner Annual Service Plan for Units (see Chapter 19 on page 29).
5. To help organize new units with the Scout district executive team, district membership committee, and chartered organization representatives. Also, to help recruit leaders for the new units.
6. To work with new units that are having problems in order to keep them from "dropping" or disappearing as functioning units.
7. To help with "dropped" units that could be revitalized or restarted.
8. To assist units in recruiting and retaining youth membership by working with the council and district membership and relationships chairs to conduct a successful annual membership recruitment effort.
9. To work with the district membership committee to assist Cub Scouts in making the transition from Webelos to Scouting.
10. To work with unit leadership in improving their programming and advancement through Scouting ranks.
11. To work with units to recruit and retain quality adult leadership.
12. To work with units to get their recruited unit leaders trained in the Scouting program.
13. To work with units to ensure that leaders and youth members maintain BSA standards of uniforming and insignia.
14. To ensure that the council provides support and service to council adult volunteers in Cub Scout packs, Boy Scout troops, and Venturing crews.
15. To encourage unit leaders to attend the district and council roundtables.
16. To demonstrate concern, empathy, and support to unit leaders.

17. To help units benefit from council resources that they may be unaware of.
18. To encourage 100 percent of Cub Scouts, Boy Scouts, and Venturers in all units to subscribe to *Boys' Life* magazine.

## **CHAPTER 9. OVERALL POINTS OF IMPORTANCE FOR COUNCIL COMMISSIONERS**

1. The council commissioner should be a “true believer” in Scouting’s mission, and a role model of the Scout Oath and Scout Law.
2. The council commissioner should set a high standard of personal performance and expect accountability of each administrative and unit commissioner in the council.
3. To best accomplish these responsibilities, the council commissioner should take personal ownership of the council’s Scouting program and sees it as their duty to enthusiastically do whatever it takes to improve the program. That type of true leadership is what’s needed in the role of council commissioner and will go a long way in accomplishing their goals.
4. The council commissioner should set and make known the vision and goals for their term of service. These should be consistent with the BSA’s mission and vision statements, the council commissioner’s responsibilities as noted in this manual, and the needs and plans of the council.
5. The council commissioner should be in a proper Scout uniform at most meetings and functions to set the example for the volunteer leaders. They can check with the Scout executive to see which event or meetings are the ones where the council commissioner should be in uniform.
6. To set an example throughout the council, the council commissioner should consider making a significant contribution to the council’s Friends of Scouting annual campaign and/or the council’s endowment campaign.
7. Although many councils prefer someone who was involved in Scouting as a youth and/or who has extensive Scouting experience as an adult volunteer, there are no specific requirements for being appointed to council commissioner. Some councils select someone who has been involved in commissioner service and who has many years’ experience in various commissioner positions in the council. However, there are numerous examples of persons having been selected with little or no previous Scouting experience, but who could quickly learn and perform the responsibilities and duties noted in this manual.
8. The council commissioner is elected at the council executive board’s annual meeting and can be removed by a vote of the council executive board at any time.

## **CHAPTER 10. THE ROLE OF THE COUNCIL PRESIDENT IN RELATIONSHIP TO THE COUNCIL COMMISSIONER**

- The council president is the chief volunteer officer of the council.
- The council president is the chair of the council board and is responsible for leading a 501(c)(3) not-for-profit organization (see Chapter 13 on page 24).
- These leadership responsibilities are shared with the Scout executive and council commissioner as a part of the council Key 3.

- The president meets and greets the public and is the face of the council.
- Working together with the council nominating committee, they should fill key board and committee vacancies and replace inactive committee chairs and board members.
- The council president sets priorities and objectives consistent with the council's strategic plan.
- The council president can include major council issues on the council executive board's agenda.
- Most important, the council president should know the council's progress toward its goals and objectives.

## **CHAPTER 11. THE RELATIONSHIP OF THE COUNCIL PRESIDENT TO THE SCOUTING PROFESSIONAL STAFF**

- The professional staff provides guidance while the volunteer provides leadership and renders service.
- The Scout executive and president must be open and honest with one another and have a good working relationship.
- The direction of the council professional staff must come from the Scout executive only—not the council president or other board members.
- In the unlikely event of a disagreement between the council president and the Scout executive, the board should make the final decision.
- The president should check with the Scout executive before making any public statement.
- The Scout executive should be the news source or spokesperson in emergencies.
- The council president should always keep in mind that the council's Scouting program should be volunteer-led and professionally guided.

The council president, in addition to expected attendance at council executive board, council executive committee, council Key 3 meetings, and the Scout executive's review and annual salary review meeting, is welcome to attend:

- BSA National Annual Meeting
- Council camporees
- United Way site visits
- Area conferences
- Council finance committee meetings
- Summer camp
- Council charter reviews

The Scout executive will work with the council president to decide which meetings and events are most important to attend.

## **CHAPTER 12. THE ROLE OF THE COUNCIL SCOUT EXECUTIVE IN RELATION TO THE COUNCIL COMMISSIONER**

- The Scout executive works together with the council commissioner and the council president to maintain national Scouting program standards and the continuity of the council's Scouting organization and program operations.

- The Scout executive is the chief executive officer of the not-for-profit, 501(c)(3) council executive board, and as such is responsible for fulfilling the policy decisions and strategic plan of the council executive board, of which the council commissioner is a member.
- The Scout executive is hired and fired by the council executive board.
- The Scout executive leads the local council, which is an administrative organization charged with fulfilling the purpose of the Scouting movement.
- Scouting is a volunteer movement that operates with professional guidance.
- The Scout executive recognizes and is committed to the predominant and vital role of volunteer Scouters at all levels in fulfillment of their responsibilities.
- Roles of the council Scout executive:
  - Professionally trained representative of the national Scouting program
  - Chief executive officer of the local council
  - Corporate secretary for the council executive board and committee
  - Counselor and adviser to the council president and council commissioner
  - Director of professional and support team members

## **CHAPTER 13. THE COUNCIL COMMISSIONER'S RESPONSIBILITIES AS A COUNCIL EXECUTIVE BOARD MEMBER**

Because of the strong, 100-year-old national organization, it's easy to forget that each BSA council is incorporated as a separate, legal entity—a 501(c)(3) not-for-profit organization with an independent governing board—independently chartered by the BSA to provide the Scouting program. In essence, the Boy Scouts of America is a federation of all of its councils. This is analogous to councils themselves chartering independent packs, troops, and crews at various schools, churches, and other organizations.

As an independent entity, each council has certain legal, fiduciary, and moral responsibilities to fulfill within its local community. Therefore, it's important that the council commissioner, as a member of the council executive board, understands their basic responsibilities as a council executive board member. They are:

1. Set the mission of the council and review it from time to time.
2. Be committed to the mission, values, and goals of the Boy Scouts of America.
3. Hire/fire the Scout executive.
4. Fiduciary responsibilities.
5. Quality of the Scouting program.
6. Strategic planning.
7. Fundraising.
8. Board development (nominating committee).
9. Observe conflict-of-interest policies.
10. Attend, participate, and vote at council executive board meetings.
11. Manage council issues from a policy perspective.
12. Work as a team.

As the council's top uniformed volunteer, the council commissioner is seated on the council executive board with the basic responsibility of representing all uniformed adult volunteers in council matters. However, the council commissioner does not vote from this single perspective, but uses good judgment to vote on all council matters for the good of the council overall.

As noted before, the council executive board president's responsibility is to preside over the council executive board and fulfill the 12 responsibilities listed above.

The following clarifies the distinction between the council executive board's governing role and the Scout executive's administrative role:

Board governance sets policy and strategy, makes large decisions, and oversees implementation.

Scout executive implements policy and strategy as set forth by the board, manages day-to-day operations, and achieves goals.

In summary, the council executive board has three primary roles:

- Policy formulation
- Decision making
- Oversight

There are also three legally mandated duties of council executive boards:

- The duty of *care and due diligence*

The board must be knowledgeable of all reasonably available council information and act with appropriate prudence and care. It's not acceptable for a board member or the council commissioner to later say that they were unaware of something.

- The duty of *obedience*

The board must ensure that the council is obedient to its central core purpose as described in its articles of incorporation and to the BSA's mission statement.

- The duty of *loyalty*

The board must discharge its duties unselfishly to the benefit of only the council and not the council executive board members personally. This means that board members should:

- Disclose situations with potential conflicts of interest and self-interest.
- Avoid competition with the council.
- Refrain from discussing confidential board business with others.

## **CHAPTER 14. THE ROLE OF THE COUNCIL COMMISSIONER AND THE BOARD IN PROGRAM/QUALITY**

The council executive board is responsible for the development and review of quality assurance, compliance, and monitoring systems, and for regularly evaluating the council's Scouting programs. This is a responsibility that the board cannot delegate to the council commissioner or the Scout executive alone. The board is ultimately responsible for what does or doesn't happen within the council relating to the quality of the Scouting program. The board is also ultimately responsible for the actions of the council's paid professional staff and the volunteers performing their responsibilities in implementing the program. The board has the ultimate responsibility for the quality of the Scouting program that the youth receive and they should review it regularly. They should ask the

Scout executive and council commissioner frequent questions about the quality of the program and follow up on these questions as a part of their oversight responsibilities.

The council commissioner is responsible for relaying any board issues or concerns to the other volunteers through the commissioner's administrative structure.

The council commissioner should be intimately familiar with the Scouting program and should intuitively know a good program when they see it. In addition, the commissioner should inform the other members of the Key 3 and the board of any complaints, concerns, or issues that the commissioner or volunteers may be expressing.

In order to fulfill the oversight role related to quality and programming, the council commissioner should regularly attend various meetings and council and district functions, observing, listening, and talking to volunteers.

## **CHAPTER 15. THE COUNCIL COMMISSIONER'S VISION STATEMENT**

One of the most important things a council commissioner should do comes at the very beginning of their term of service. The council commissioner has a responsibility to set a vision for the commissioner team. This is what the council commissioner hopes the commissioner service will accomplish under their leadership, and what they hope will be the legacy of their service to the council. The council commissioner should write a vision statement.

A vision statement is putting into words what success will look like for a particular effort. The following is a list of steps to develop a council commissioner's vision statement.

1. It is important to consider the council's current situation. A careful assessment of unit strength, membership, unit retention, and the current commissioner team and their functioning will reveal that.
2. The next step involves thoughtful consideration. What areas need the most attention? What needs to be added to or changed about the current council's commissioner service? Focus on what needs to happen rather than how. Make some notes and think about the big picture. This is the opportunity to make significant improvements in the quality of commissioner service delivered to the units of the council.
3. Write down a simple statement describing the objectives.
4. Determine the gaps between where the council's commissioner service is now and where you want it to go. Make some notes about how to get from here to there. The list may seem overwhelming, but go slow. This is not a quick fix.
5. Choose two or three of the most important strategic ideas that will help bring the vision for commissioner service into reality. Make some plans that will help move along the agenda toward those ideas. These become the annual goals.
6. Break the goals down into action plans—each should have a responsible individual and a due date. These are the operational plans for the coming year. Make sure that each fits into the vision of success.
7. It is important that during their term the council commissioner reviews these goals every six months, making sure progress is being made toward achieving them. As the vision for commissioner service becomes reality, the commissioner should continue to set new, higher goals and visions.

### Summary

By setting worthy and specific goals for their time as council commissioner, the council commissioner will have an impact on a large number of commissioners, who in turn will have an impact on a large number of units and Scouts. The result of this vision, planning, and goal setting will be the program improvements the Scouts receive.

## CHAPTER 16. ENSURE HIGH-QUALITY COMMISSIONER SERVICE FROM ADMINISTRATIVE COMMISSIONER STAFF

### 1. Define their responsibilities

Administrative commissioners must know what is expected of them in order to be successful. Make sure each one knows, in writing, the responsibilities of their position. There are many official BSA materials in which these responsibilities are articulated.

### 2. Select and recruit

Fit the right person to the position. Consider each person's skills, interests, and other relevant factors. Consider the variety of motivating factors for people getting involved in Scouting. Use all the prescribed steps and methods in recruiting administrative commissioners. Use the recruiting resources provided by the BSA.

### 3. Orient and train

Provide each recruited administrative commissioner with a prompt orientation (Fast Start) and Basic Commissioner Training. Orient them to their individual administrative assignment (assistant council commissioner, district commissioner, etc.). Provide ongoing training over time.

### 4. Coach your administrative commissioner team

Provide ongoing, individual coaching as needed. Build up their confidence and self-esteem. Being an administrative commissioner is a hard, complex task. New commissioners need to feel confident in order to do well. Additional coaching should be provided by the appropriate-level administrative commissioner.

### 5. Recognize their service

Prompt volunteer recognition has an important impact on the tenure and quality of commissioner service. Recognition must be sincere, timely, and earned. Use the great variety of formal BSA recognition items, but also be creative with frequent "thank yous" or a personal note. Recognizing commissioners in front of peers at council or district functions will be well received by them.

### 6. Evaluate administrative commissioner performance

Regularly evaluate how administrative commissioners at all levels are doing. Use the BSA responsibility descriptions and evaluation materials available. Make personnel changes promptly when necessary.

## CHAPTER 17. ASSISTANT COUNCIL COMMISSIONERS

Successful council commissioners know they cannot do their task alone. Council commissioners surveyed had an average of three to five assistants. Appointed by the council commissioner, the assistant council commissioners may play the following roles:

- A **"stand-in."** Like the vice president of an organization, an assistant council commissioner can be appointed by the council commissioner to act as a substitute when they are temporarily unable to serve (e.g., out of town, ill, etc.).
- A **"copilot."** A good assistant does more than wait for emergency action. An assistant should share the weight of leadership as determined by the council commissioner. There are many ways the assistant can help. For example, by handling topics at the council commissioner's cabinet meetings or helping to guide a new district commissioner.

- On “**special assignment.**” The council commissioner might ask assistants to undertake special ongoing assignments. This is the most popular role of the assistant. Seven special assignments are listed in order of popularity.
  1. **Training.** The assistant council commissioner for training coordinates commissioner training in the council, sees that basic training is available somewhere in the council during all parts of the year, trains district commissioner trainers, and sees that the concept of “continuing education for commissioners” really works.
  2. **Geographic service area.** Councils with eight or more districts often have assistants who provide special support as needed for clusters of districts in various parts of the council. The assistants are careful to give district commissioners their rightful direct responsibility for operation in the districts. Council assistants make themselves available for guidance and help where needed.
  3. **Roundtables.** Many councils have assistants to help in training district roundtable personnel by bringing them together twice a year to exchange ideas, share new ways of promoting attendance, create active program features, and handle roundtable logistics.
  4. **Program.** Some councils have assistant council commissioners for Cub Scouting, Boy Scouting, Varsity Scouting, Venturing, and Exploring.
  5. **Commissioner Conference.** Some councils have assistant council commissioners who lead the team that runs the annual council commissioner conference (a College of Commissioner Science or non-college conference).
  6. **Diversity.** Some councils have an assistant council commissioner who works with districts to encourage diversity of commissioners on their teams, as well as helping to serve the emerging markets of their respective districts.
  7. **New-Unit Service.** Some councils have created an assistant council commissioner to coordinate the efforts in working with new units to provide a more focused emphasis on their first three years of operation.

## CHAPTER 18. MEETINGS

Not many people enjoy meetings, but the council commissioner, by virtue of their central role in the council, will be involved in many of them. Examples of some of the meetings the council commissioner needs to attend are:

- Council Key 3 meetings
- Council executive board meetings
- Council board meetings
- District meetings, if invited
- Council commissioner’s administrative team meetings
- Council charter reviews
- Other council functions (events, fundraisers, awards dinners, etc.)

The council commissioner should, with the Scout executive and Scout president, also regularly visit other council and district committee meetings, where their presence can be of assistance, or just to be seen and to listen to input.

Also, because they are a member of the council Key 3, the council commissioner is invited to attend the BSA’s National Annual Meeting as a council representative and as a voting member of the National Council. These meetings are held in various major cities around the country every year and have general interest and specific training sessions for council commissioners. Also, the Philmont Training Center offers numerous classes

throughout the summer that are beneficial to council commissioners, as well as classes specific to council commissioner training.

## **CHAPTER 19. THE COMMISSIONER ANNUAL SERVICE PLAN FOR UNITS**

The council commissioner is responsible for seeing that the unit commissioners bring up these subjects, in these months, during their monthly unit visits, and record it in the Unit Visit Tracking System (UVTS).

January	Review unit health
February	Commitment for Quality
March	Spring roundup
April	Inventory of unit leaders
May	Inspect troop uniforms
June	Confirm summer program
July	Review unit health
August	Planning unit program
September	Promote leader training
October	Inspect pack/troop uniforms
November	Youth Protection unit
December	Submit Quality Unit application

See other commissioner training materials for in-depth discussions and explanations of these subjects. It should be noted that this is just one example of a commissioner annual plan for units, and there are numerous other examples available. Council commissioners can also customize these plans to the specific needs of their councils.

## **CHAPTER 20. THE COUNCIL COMMISSIONER'S ANNUAL CONFERENCE AND THE COLLEGE OF COMMISSIONER SCIENCE**

- The Council Commissioner's Annual Conference

A commissioner conference should be held on an annual basis and should be the commissioner's highlight of the year. The conference should be a highly informative planning, morale-enhancing, and team-building event. However, there are several types of commissioner conferences. Some councils run a traditional conference or "retreat," and some use a College of Commissioner Science program formatted after college courses and degrees.

- The College of Commissioner Science

This program uses the terminology of college courses of study. There are bachelor's, master's, and doctoral programs. A diploma is awarded to each participant who completes the requirements of the "degree." The awards are called:

- Bachelor of Commissioner Science
- Master of Commissioner Science
- Doctorate of Commissioner Science

This format encourages an ongoing continuing education experience for commissioners by offering a number of instructional classes at each level. A commissioner may attend/teach several classes throughout a day. The college may be held in a single day or over a weekend. The reasons for offering a number of courses are to provide ongoing practical training for all commissioners—administrative, roundtable, and unit commissioners—on a variety of subjects. The courses typically offer real-world advice and training from experienced commissioners.

## **CHAPTER 21. REQUIRED AND SUGGESTED COUNCIL COMMISSIONER TRAINING AND AWARDS**

To set a good example for all the commissioners in a council, the council commissioner is required to undergo certain training, and it is suggested that they work to achieve additional recognition awards.

- |                  |  |
|------------------|--|
| <u>Required</u>  | 1. Online “Fast Start” video for all commissioners |
| <u>Required</u>  | 2. Basic Commissioner Training                     |
| <u>Suggested</u> | 3. Arrowhead Honor                                 |

There are specific Arrowhead Honor awards for various categories of commissioners:

- Unit commissioner
- Roundtable commissioner
- District commissioners and assistant district commissioners
- Council commissioners and assistant council commissioners
- Area commissioners (proposed)

These awards have requirements involving service, training, and performance, and completion of these awards signifies the ability to put commissioner training into practice. Only commissioners may wear the Arrowhead. See specific requirements in other BSA publications.

- |                  |  |
|------------------|--|
| <u>Suggested</u> | 4. Commissioner Key  |
|                  | A commissioner must complete the Arrowhead Honor (above) and serve in a commissioner position for three years within a five-year period. |

- |                  |   |
|------------------|---|
| <u>Suggested</u> | 5. Doctorate of Commissioner Science Knot Award |
|------------------|---|

The purpose of the Doctorate of Commissioner Science Knot Award is to recognize completion of a standardized program leading to the completion of a thesis or project and the award of the Doctorate of Commissioner Science from a College of Commissioner Science.

The College of Commissioner Science program is designed to have a commissioner learn through a series of training classes, followed by work experiences, to ensure a quality program throughout Scouting. This training will take a number of years to complete.

In order to obtain the Doctorate of Commissioner Science Knot Award, the commissioner must earn or accomplish A, B, C, and D below:

- A. Bachelor of Commissioner Science Degree
- B. Master of Commissioner Science Degree
- C. Doctor of Commissioner Science Degree, and complete a thesis or project
- D. Performance (all three below are required):
  - Serve on the College of Commissioner Science faculty.
  - Recruit at least three new commissioners at any level. Approval of council or assigned commissioner is required.
  - Be approved for the knot by the Scout executive or the adviser to commissioner service.

## **CHAPTER 22. A CHECKLIST OF CHARACTERISTICS OF A COUNCIL COMMISSIONER**

Obviously, the role of the council commissioner is multi-faceted, and there is not one prescriptive list of individual characteristics that someone could or should possess in order to be an effective council commissioner. However, there is a list of traits and skills that are common to many successful commissioners:

- Has an intimate knowledge of the Boy Scouts of America program.
- Was in the Scouting program as a youth.
- Has volunteered at the district or council level for a significant number of years.
- Has a thorough understanding of the role of the unit commissioner, and/or various administrative commissioner positions.
- Loves Scouting and embraces the Scouting mission.
- Has a significant amount of time available for this demanding volunteer position.
- Enjoys meeting and dealing with other people.
- Likes holding, organizing, and conducting meaningful meetings.
- Enjoys and is good at communicating with others.
- Is able to understand complex problems and devise solutions.
- Has a sense of humor.
- Is able to write and speak well.
- Enjoys presenting in public meetings.
- Is a role model for other commissioners and volunteers.

These are in no particular order, and there is no particular number of these traits that are necessary to constitute a successful council commissioner. However, the more of these characteristics the council commissioner possesses, the more likely it is that they will be successful in this challenging role.



**The District Commissioner  
and  
Assistant District Commissioner**



## **CHAPTER 23. THE DISTRICT**

Each council is subdivided into a number of districts. The number varies by council, but usually they are geographic sub-areas of the council.

Each district has its own administrative structure and is governed by the district Key 3 (refer to Chart E on the following page).

CHART E

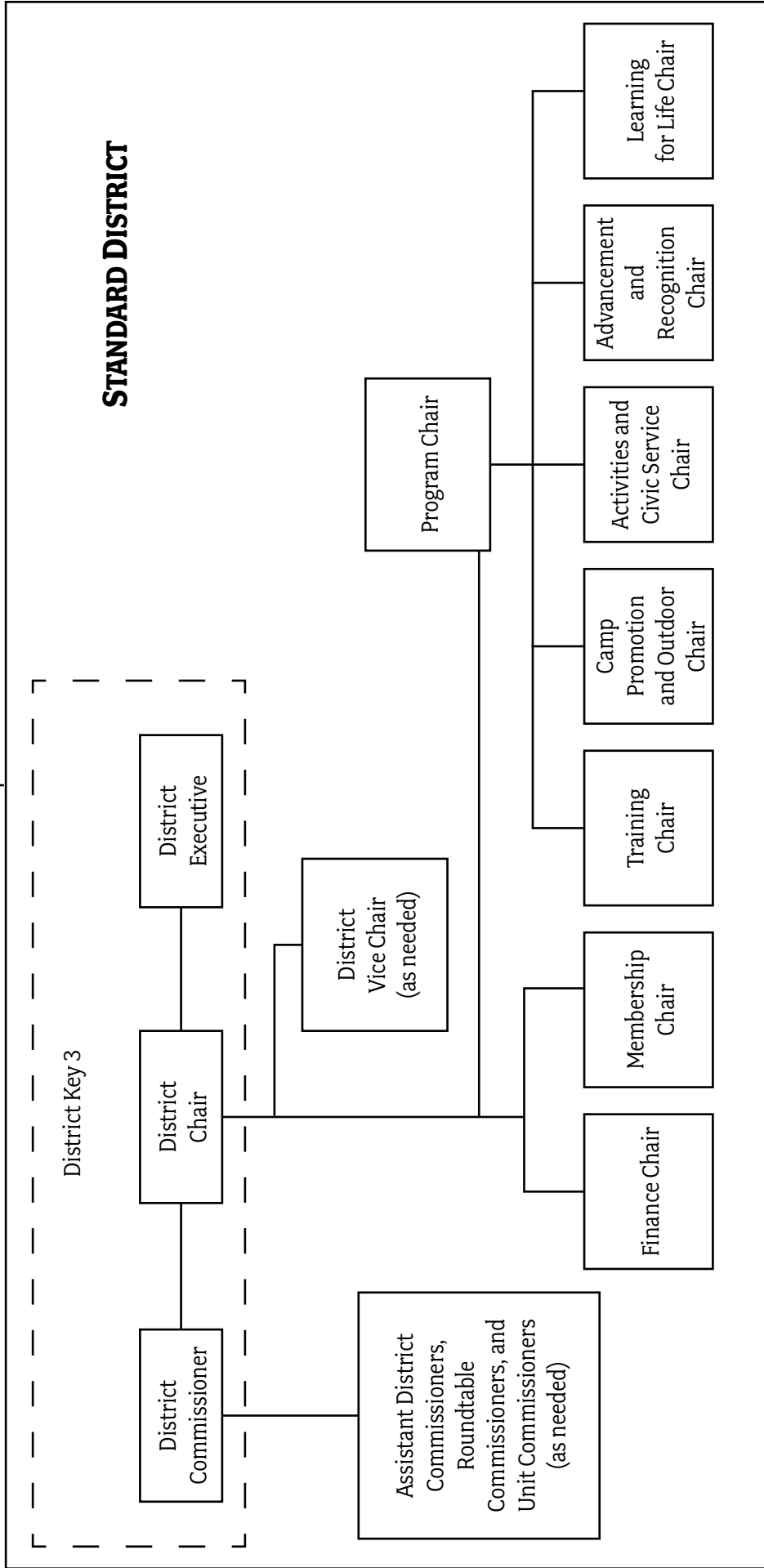
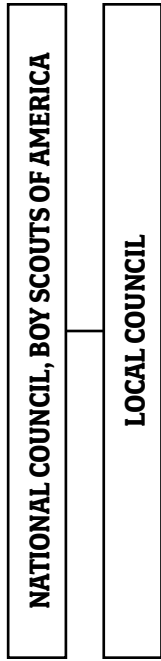

CHARTERED AND PARTICIPATING ORGANIZATIONS  
PACKS • TROOPS • CREWS • POSTS

## **CHAPTER 24. THE DISTRICT'S PURPOSE**

A Scouting district is a geographical area of a BSA local council, determined by the council executive board. District leaders mobilize resources to ensure the growth and success of Scouting units within the district's territory.

The purpose of the district is to work through chartered organizations and community groups to organize and support successful units. The end result of effective district support is more and more youth members receiving a better and better program.

## **CHAPTER 25. THE DISTRICT'S RELATIONSHIP TO THE COUNCIL**

The local council establishes districts, each a prescribed part of the council's geographic territory, for the purpose of unit service and program administration, and has the authority to realign district territories. It also has the authority to oversee the organization of district committees and district commissioner team to administer Scouting in the districts and to disband districts.

Only the local council is chartered by the Boy Scouts of America. The district is not chartered. Each district exists only by authority of its local council.

The local council is chartered and held responsible by the Boys Scouts of America for the administration of Scouting in its entire territory with adherence to basic policy, maintenance of standards, public acceptance and goodwill, providing facilities necessary to good Scouting, organization of new units, service to existing units, and the quality of the program that each youth member receives.

The district exists as a part of the council. The council adopts overall policies and plans a program designed to meet the needs of every part of the council's territory. The district, which had an important part in that planning, carries out the programs so that it reaches and helps every chartered organization and unit. The district committee is not a legislative body in the same sense as the council executive board. It does uphold BSA policy in its own local area, but it can neither make basic changes nor permit violations of established policies. The council executive board is the governing body of the entire council and is responsible for its operation and assets. It is an independently incorporated, 501(c)(3) not-for-profit organization, but the district is not. The district is an operating subunit of the council.

The district cannot raise money in the name of Scouting, nor permit others to do so, except in campaigns authorized by the council. The district cannot hold titles for property or accept gifts. The council is the only agency that can do so. Thus, there is no such thing as a district-owned camp or fund. There may be a campsite and camp property located in district territory and used principally by that district, but the property title is held by the council. Districts also do not have budgets, treasurers, or treasuries.

The district chair, district commissioner, district executive, and district operating committee chair all provide important ties to the overall council organization.

## **CHAPTER 26. THE FOUR FUNCTIONS OF THE DISTRICT**

All districts are responsible for carrying out four important standard operational functions:

1. Membership

The membership function strives for growth throughout the district with new Scouting units and growth through new members joining existing units.

2. Finance

The finance function sees that the district provides its share of funds to the total council operating budget.

3. Program

The program function concentrates on helping Scouting units provide the official Scouting program, camp promotions, and special activities, including community service, training adult volunteers, and youth advancement and recognition.

Note: For more information about membership, finance, and program functions, see the BSA publication *The District*.

4. Unit Service

The unit service function provides direct coaching and consultation by district volunteers and commissioners to adult leaders to ensure the success of every Scouting unit.

Note: The membership, finance, and program functions are carried out by members of the district committee. The unit service function is carried out by the district commissioner team.

The order in which the functions are listed above is not meant to suggest the order of their importance, but instead is the natural interrelationship and flow of the functions. The Scouting movement cannot achieve its purpose without first organizing units and enrolling members. The district cannot support its units without the funds to do so, and unit programs are supported by the district through its program functions and unit service. All four functions are equally important and necessary. If one suffers from lack of attention, the work of the entire district suffers.

## **CHAPTER 27. THE DUTIES OF THE DISTRICT COMMISSIONER**

1. Recruits, appoints, trains, supervises, and motivates the assistant district commissioner and unit commissioner team so all units in the district receive regular helpful service or assistance from a unit commissioner.
2. Conducts monthly meetings with the district commissioner team to review the health of each unit and plan who will help meet specific unit needs during the month ahead.
3. Directs commissioners to establish and maintain a system of frequent visits to each unit, receives reports of problems in the units through regular meetings of the district commissioner's team, and reviews plans to solve such problems.
4. Directs the unit commissioners to report and record their unit visits with the Internet-based Unit Visit Tracking System (UVTS).
5. Oversees the unit charter renewal plan and procedures to ensure that each unit reregisters on time and with optimum membership.
6. Attends district and/or council meetings, and reports on the condition and needs of units. Keeps current on all developments and new ideas, including the use of program planning tools, and sees that units are informed.
7. Serves as a member of the district Key 3, and meets regularly with the district chair and district Scout executive to coordinate the work of the district and assess its progress.
8. Works closely with roundtable commissioners to ensure quality roundtables that are well-attended.

9. Encourages the commissioner team to have all units on the unit budget plan, thus encouraging all units to subscribe 100 percent to *Boys' Life*.
10. Serves as a member of the council commissioner's team and attends meetings to represent the district.
11. Helps all units (Cub Scout packs, Boy Scout troops, and Venturing crews) to be successful and provide an increasingly better Scouting program for the youth of the district.
12. Participates in the council's commissioner conferences or the College of Commissioner Science under the leadership of the council commissioner.
13. Supports local and national Scouting policies, procedures, and practices.
14. Recruits and directs roundtable commissioners who report to the district commissioner and are responsible for planning and operating successful Cub Scout, Boy Scout, and Venturing leader roundtables each month.

## **CHAPTER 28. THE ROLES OF THE DISTRICT COMMISSIONER**

- The district commissioner works directly with the district chair and the district professional Scouting staff as part of the district Key 3.
- Districts may have one or more paid professional Scouting staff members .
- District professional Scouting staff can carry one of the following titles:
  - District executive
  - Senior district executive
  - District director

## **CHAPTER 29. THE RESPONSIBILITIES OF THE DISTRICT COMMISSIONER**

- The major expectation of the district commissioner is unit service. They should take ownership of the district team of commissioners and ensure that all units are well cared for throughout the year. Most important is the monthly unit commissioner contact with each unit. The contact could be face to face whenever possible so the commissioner can make an objective assessment about the health of the unit. If this is not possible, phone, e-mail, or voicemail contact is acceptable.
- The district commissioner should help unit commissioners pay special attention to new units. These are the most vulnerable to “dropping.” The district commissioner should also work with the district membership chair to help recruit Scouts and leaders.
- The district commissioner must be a proven leader capable of enlisting other effective persons to serve. The district commissioner is the chief morale officer of the district and should be upbeat, personable, determined, and a role model for Scouting ideals. They should be passionate about the benefits of Scouting and a champion of the unit to make Scouting happen in the lives of young people.
- The district commissioner understands and communicates the best skills available in unit service: how to counsel, coach, and inspire unit volunteers; how to enrich the unit program; and how to help units solve problems before problems “sink” the unit.

- District commissioner meetings

The district commissioner is expected to attend a significant number of meetings of various kinds throughout the year. Some of these are:

- Council-level meetings:
  - Council annual meetings
  - Council Silver Beaver Award presentation meeting
  - Council commissioner meetings
  - Annual Key 3 Scouter training
  - Annual commissioner conference
  - Annual College of Commissioner Science
- District-level meetings

The district commissioner conducts the monthly district commissioner's team meeting. This should ideally be on a day separate from all other district meetings, and it should absolutely not be combined with other district meetings. This will detract from the importance of the district commissioner's and the unit commissioner's functions within the district.

- District committee meetings

The district commissioner has a role in the district committee monthly meetings, and from time to time might also need to represent others in the district Key 3 that are not present at this meeting. The district commissioner may also need to attend:

- District roundtable meetings
- District camporees
- District courts of honor and events

- Unit Visit Tracking System (UVTS)

The district commissioner is responsible for ensuring that all unit commissioners regularly use the Internet-based Unit Visit Tracking System to report their unit contacts.

- Training and recognition

It is the responsibility of the district commissioner to personally attend commissioners' trainings and to ensure that all assistant district commissioners and unit commissioners on the team have attended Commissioner Basic Training and Fast Start Training. Assistant district commissioners should also attend the assistant district commissioner seminar.

- The district commissioner should ensure that assistant district commissioners and unit commissioners within the district attend the council's College of Commissioner Science and encourage individuals to potentially attend national-level training at the Philmont Training Center.
- The district commissioner should encourage commissioners to complete the Arrowhead Honor and the Commissioner Key.

- Recruiting

The primary job of the district commissioner is to recruit enough assistant district commissioners and unit commissioners to be able to ensure there is one unit commissioner for every three units in the district, and that there is one assistant district commissioner for every five unit commissioners, meaning each assistant district commissioner will have 15 units under their supervision. These are the national BSA target ratios, but a district is allowed to recruit more commissioners than this if they feel the need.

- District committees

The district commissioner also works with the district operating committees. These committees meet to deal with the following four functions of district operations:

- Program
- Membership
- Finance
- Unit service

- Tools available

There are many BSA resources available to district commissioners, including manuals, Fast Start trainings, websites, podcasts, and others.

## **CHAPTER 30. THE DISTRICT COMMISSIONER TEAM**

The district commissioner team, led by the district commissioner, includes assistant district commissioners, roundtable commissioners, and unit commissioners.

The district nominating committee, after consulting with the district Scout executive, should recommend a district commissioner to the council executive board for appointment and approval, with the concurrence of the council Scout executive and council commissioner.

The district commissioner works closely with the district chair and the district executive. They are known as the district Key 3.

## **CHAPTER 31. HOW LARGE IS A DISTRICT COMMISSIONER TEAM?**

The size of a district commissioner team is determined by the needs of the district. Unit commissioners typically function at their best when they serve three units. Therefore, a good rule of thumb is to divide the number of units by three, then recruit that number of unit commissioners. Being responsible for the success and well-being of three units and their leaders is a full-time volunteer task. There should be an assistant district commissioner for every five unit commissioners.

Refer to *Commissioner Administration of Unit Service* and the *Commissioner Fieldbook for Unit Service* for more information.

## **CHAPTER 32. THE TEST OF AN EFFECTIVE DISTRICT COMMISSIONER TEAM**

- Your district has a full team of trained commissioners (assistant district commissioners, roundtable commissioners, and unit commissioners).
- All of the district units are visited monthly by a commissioner, who utilizes the Commissioner Annual Service Plan for Units (see Chapter 19 on page 29) on these visits and reports them on the Unit Visit Tracking System (UVTS).
- There is an increasing percentage of district units rechartering on time each year.
- There is an increasing percentage of district units achieving the Quality Award status each year.
- There is an increasing youth retention rate at charter renewal times.
- There are fewer units “dropping,” and more are being formed and chartered.

## **CHAPTER 33. HOW TO BE SUCCESSFUL AS AN ASSISTANT DISTRICT COMMISSIONER**

- Assistant district commissioners can make or break a district's ability to see that every unit receives competent commissioner service. Even the best district commissioner in the council cannot personally train and guide all unit commissioners. (In a 60-unit district, that is at least 20 unit commissioners.) Therefore, assistant district commissioners are assigned certain units in the district, and they supervise the unit commissioners who serve those units. Assistant district commissioners are appointed by district commissioners.
- Listen to and work with the district commissioner. Communicate through this district commissioner unless the council commissioner has requested direct communication from you.
- Review and confirm that the district commissioner team has a complete and clear organizational chart, with assistant district commissioners typically managing no more than five individual unit commissioners. Each unit commissioner should have three or fewer units.
- Ensure that there is a roundtable commissioner for each roundtable. Roundtable commissioners need to recruit their own specialized team to assist them, and need to attend the quarterly roundtable commissioner meetings in order to plan and coordinate.
- Help the members of the district Key 3 achieve their goals.
- Ask district Scouting professionals to share their "SMART goals." These are the basis for their annual review, promotion, compensation, and therefore, retention. The goals of the district committee and district commissioner team should be designed to ensure that the district Scouting professionals meet or exceed their "SMART goals," and the district and assistant district commissioner should help them do this.
- Keep the unit commissioners focused on unit service. There are many other things to distract them from the essential goal of visiting units and reporting these through the Unit Visit Tracking System (UVTS).
- Focus on the district goals. Usually these are driven by the membership and finance committees, which follow the Scouting program. Therefore, it's also important to focus on making sure each unit and district has a quality program.
- Focus on the council's outdoor program and getting youth to attend outdoor camps and summer camps.
- Good assistant district commissioners have strong people skills. They also:
  - Help recruit the right people
  - Provide clear instructions and specific ideas for their team
  - Listen to what people say and feel
  - Never play favorites
  - Coach unit commissioners through real unit problem-solving situations
  - Treat all Scouters with courtesy and dignity
  - Praise each commissioner often for specific achievements
  - Do not try to take over for their commissioner team, but always are ready to support or help them to be successful
- Assistant district commissioners work closely with the district commissioner and district executive. This team must have a vision of effective Scouting, and they must communicate that vision through unit commissioners to every unit leader in the district.

- When a unit commissioner resigns or cannot adequately fulfill the responsibilities of the position, the assistant district commissioner temporarily assumes the vacant position. However, immediate action must be taken to recruit a replacement. Administrative commissioners are not unit commissioners. Their responsibility is to find unit commissioners.
- Assistant district commissioners measure unit commissioners' progress, not in the number of meetings they attend, but in the way they handle their responsibility of visiting units.
- The assistant district commissioner's role is accomplished largely on a personal basis. At monthly district commissioner team meetings, they help their unit commissioners plan how to help meet priority needs of units. They also hold their commissioners accountable for the previous months' plans and assignments.

## **CHAPTER 34. THE ROLE OF THE DISTRICT EXECUTIVE (PROFESSIONAL SCOUTING STAFF)**

The district executive is an ex officio part of the district commissioner team. This professional Scouting leader is approved and appointed by the council executive board, with the concurrence of the Scout executive. The district executive works with the districts to:

- Maintain contact with the unit chartered organizations in the district.
- Support volunteers—unit leaders and commissioners.
- Provide information from the council service center.
- Support the four functions of district operations (see Chapter 26 on page 37).
- Districts without currently assigned professional staff are normally serviced by the field director for that service area.
- In working with the district executive, the correct orientation is to work with them as a peer. It's not uncommon for the district commissioner to be older than the district executive, but they should not relate to the district executive as a son or daughter. Instead, they should relate as equals. The district commissioner should help the district executive succeed. A common role for the district commissioner is to act as a mentor or coach to the district executive, working to develop a meaningful working relationship.



# **The Unit Commissioner**



## CHAPTER 35. THE ROLE OF UNIT COMMISSIONERS

Throughout this manual, the council commissioner has been described as the person responsible for overseeing the functioning of the volunteers on the council commissioner's team. The specific duties of the unit commissioners have been listed in Chapter 8 on page 21. There are many BSA training manuals, courses, fact sheets, and other resources to familiarize unit commissioners with their role. The following is a summary of their vital functions and relationships to Scouting's unit leaders.

### Friend

- Most important role.
- "I care. I am here to help. What can I do for you?"

### Representative

- You represent the BSA, the council, and the district.
- Set a good example.

### Doctor

- Be like a country doctor making house calls.
- The prevention is better than the cure.

### Teacher

- Share knowledge.
- Teach adults and youth.

### Counselor

- Help unit solve problems.
- Best role when unit does not recognize problem.

## CHAPTER 36. THE UNIT COMMISSIONER'S SERVICE FUNCTION FROM THE UNIT LEADER'S PERSPECTIVE

The Scouting movement rests upon two assumptions:

1. That unit leaders can use the Scouting program to make a difference in the lives of young people.
2. That district volunteers will do whatever is necessary to ensure the success of every unit leader.

Here's the way it is for unit leaders; let's use the Scoutmaster for our example:

One night every week, the Scoutmaster knows there will be a group of Boy Scouts waiting at the troop meeting location. It makes no difference whether the Scoutmaster brings a headache home from work, is tired, or would rather be doing something else. He knows if he doesn't appear at the troop meeting, the boys will lose faith in him.

If he hasn't held enough meetings of the patrol leaders' council, his boy leaders will not function, and he'll have to run the meeting alone. All of that, and more, is important to the Scoutmaster, because he takes it seriously. He knows the troop is composed of boys who need his help and guidance.

The problem is that the Scoutmaster sometimes feels alone in his role, even though it isn't meant to be that way. The community organization that operates and sponsors his troop is expected to care about what he is doing, but it isn't always easy for them to know how to help. Sometimes members of that organization have so much faith in their Scoutmaster that they let him fulfill his role alone. A troop committee exists to help him, but sometimes they wait for him to call their meetings and tell them what to do.

It's quite likely the parents appreciate all he is doing for their sons, but they may not always show it. The Scouts enjoy their experience, but sometimes they, too, take him for granted.

Considering everything a Scoutmaster must do to operate his troop successfully, he probably spends 30 to 40 hours every month dealing with all the tasks and problems. In addition, he is expected to use a week of his vacation time each year to provide a long-term camping experience. Although the Scoutmaster likely enjoys time spent with the Scouts and feels satisfied with the good work he's doing, it is still a demanding volunteer position. It's not surprising if he becomes discouraged and frustrated once in a while.

It is in those moments that a Scoutmaster feels alone and wonders if it's worth the effort. It's one thing if his troop's chartered organization forgets him, or if the troop committee isn't very helpful, but it's almost devastating if the Boy Scouts of America seems to be neglecting him. If a unit leader has an effective unit commissioner, they will never feel alone.

## **CHAPTER 37. THE NATURE OF COMMISSIONER UNIT SERVICE**

The most important thing a commissioner does for a unit leader is to be a friend. The commissioner is the connecting link between the local council of the Boy Scouts of America and the unit leader. When the unit leader is discouraged, it is the commissioner who encourages. When the unit committee is not helping enough, it is the commissioner who meets with it on behalf of the unit leader. Even when there are no problems, it is the commissioner who works closely with the unit leader to prevent them and to prove the district cares.

There is a simple formula for success: The unit commissioner is assigned not more than three units, and is responsible for their success and the well-being of their leaders. This person does at least two things a month for each unit.

1. The commissioner attends a unit meeting or unit committee meeting, and stays long enough to evaluate how things are going and to talk with the unit leader. The commissioner should be sure to ask how things are going and how they can help.
2. The commissioner calls each unit leader between visits to see if help is needed.

These two simple acts can lift a unit leader's spirit tremendously. Even if no help is needed, it is reassuring to know it is available. Regular contacts twice a month create a positive feeling about the district and council. This is essential if a unit leader is to feel good about their role. Of course, if there is a specific problem, the unit commissioner meets with the unit leader more often until it is resolved.

Should the unit commissioner know everything about each unit's operation? While it would be nice, it isn't necessary. It is important, however, to know how to deal with common problems, and it is absolutely necessary to know where to get help with the special problems. The commissioner must care enough to never let a question go unanswered or a problem unresolved. That is the final test of a good unit commissioner.

**National, Regional, and Area Support  
Council Commissioners**



## **CHAPTER 38. NATIONAL, REGIONAL, AND AREA SUPPORT COUNCIL COMMISSIONERS**

At all levels of the BSA organization, there are commissioners available to support the delivery of a quality program experience through units to the youth they serve. The role of the national, regional, and area commissioners is to provide direct support to council commissioners and increase their understanding and service delivery to units. (See Chart C on page 14.)

## **CHAPTER 39. NATIONAL COMMISSIONER**

The national commissioner is an officer of the National Council and a member of the National Executive Board, whose duties are set forth in the bylaws of the National Council. They provide leadership to all regional commissioners in the areas of membership, unit charter renewal, and training in support of commissioner service. The role of the national commissioner is to serve as the chief morale officer of the program.

The national commissioner shall:

- Serve as a member of the national Key 3 (see Chart D on page 16).
- Work closely with all regional commissioners in providing quality commissioner service throughout the country in support of local councils.
- Supervise the activities of commissioner service, give leadership to regional commissioners, and preside at any regional commissioner meetings.
- Support the efforts to recruit commissioners at all levels of the organization in support of local councils.
- Encourage communications between regional, area, and council commissioners to ensure that all councils provide opportunities for immediate commissioner orientation, frequent basic training, and monthly learning experiences for all commissioners.
- Support councils in improving unit-to-commissioner ratios, monthly unit visits, retention of youth and units, and progress toward achieving Quality awards.
- Maintain the standards of the Boy Scouts of America and uphold all national policies.
- Provide direction and support to regional commissioners working with local councils, especially related to the membership validation process and unit charter renewal.
- Encourage the conduct and tracking of unit visits, counseling, and support related to how to handle particular national situations, recruit and train a full staff of regional and area commissioners, and support the annual commitment and achievement of the Quality awards by regions, areas, and councils.
- Work with the national president to secure the help of national, regional, and area committees in meeting local council needs.

The national commissioner reports on the status of commissioner service to the National Executive Board regularly:

- Inspirational stories about successes in local councils

- Status of each council in qualifying as a quality council, as it relates to unit visits by commissioners, and the recruiting and training of more commissioners
- Rechartering percentage of units to date, by council and area
- Retention percentage of youth and units, by council and area
- Current ratio of units to registered unit commissioners, by council

## **CHAPTER 40. REGIONAL COMMISSIONER**

The regional commissioner is an officer of the region and a member of the regional board whose duties are set forth in the bylaws of the National Council. They provide leadership to all area commissioners in the areas of membership, unit charter renewal, and training in support of commissioner service. The regional commissioner is appointed annually by the regional president for a one-year term, not to exceed three consecutive terms, with the concurrence of the regional director.

The regional commissioner shall:

- Serve as a member of the regional Key 3 (see Chart D on page 16).
- Work closely with the national commissioner, regional president, and regional director in providing quality commissioner service throughout the region and the areas in support of local councils.
- Supervise the activities of commissioner service in the region, give leadership to area commissioners, and preside at any area commissioner meetings. All regional commissioner meetings will be held in conjunction with existing meetings within the region. The regional commissioners are to support council or joint-council commissioner training courses, but are not to conduct regional or area courses.
- Support the efforts to recruit area commissioners and to provide continuing and effective commissioner service in support of each council.
- Encourage communications between the area and council commissioners to ensure that councils provide opportunities for immediate commissioner orientation, frequent basic training, and monthly learning experiences for all commissioners.
- Support councils in improving unit-to-commissioner ratios, monthly unit visits, the use of the Unit Visit Tracking System (UVTS), retention of youth and units, and progress toward achieving Quality awards.
- Maintain the standards of the Boy Scouts of America and uphold all national policies.
- Provide direction and support to area commissioners working with local councils, especially related to the membership validation process; unit charter renewal; conducting and tracking unit visits; counseling support related to how to handle particular regional situations; recruiting and training a full staff of commissioners; and supporting the annual commitment to and achievement of Quality awards by the regions, areas, and councils.
- Work with the regional president to secure the help of regional and area committees in meeting local council needs.

The regional commissioner reports on the status of commissioner service to the regional executive board regularly, including:

- Inspirational stories about successes in local councils
- Status of each council in qualifying as a Quality Council, as it relates to unit visits by commissioners, and the recruiting and training of more commissioners
- Rechartering percentage of units to date, by council and area
- Retention percentage of youth and units, by council and area
- Current ratio of units to registered unit commissioners, by council

## **CHAPTER 41. AREA COMMISSIONER**

The area commissioner, whose duties are set forth in the bylaws of the National Council, provides support to all council commissioners in the areas of membership, unit charter renewal, and training in support of commissioner service. The area commissioner is appointed annually for a one-year term, not to exceed three consecutive terms, by the regional president, upon recommendation by the area president and regional commissioner. The area commissioner reports to the area president and works closely with the regional commissioner.

The area commissioner shall:

- Serve as a member of the area Key 3 (see Chart D on page 16).
- Work closely with the regional commissioner, area president, and area director in providing quality commissioner service throughout their area in support of local councils.
- Supervise the activities of commissioner service and preside at any area meetings where council commissioners are in attendance. All meetings of the area commissioners will be held in conjunction with existing meetings within the region and areas.
- Support council or joint-council commissioner training courses, but not to conduct separate area courses.
- Encourage communications between the area and council commissioners to ensure that councils provide opportunities for immediate commissioner orientation, frequent basic training, and monthly learning experiences for all commissioners.
- Support councils in improving unit-to-commissioner ratios, monthly unit visits, retention of youth and units, and progress toward achieving Quality status.
- Maintain the standards of the Boy Scouts of America and uphold all national policies.
- Provide direction and support to council commissioners, especially related to the membership validation process, unit charter renewal, conducting and tracing unit visits, counseling support related to how to handle particular situations, recruiting and training a full staff of commissioners, and supporting the annual commitment and achievement of the Quality Council Award.
- Work with the area president to secure the help of area committees in meeting local council needs.

The area commissioner reports on the status of commissioner service to the area regularly, including:

- Inspirational stories about successes in local councils
- Status of each council in qualifying as a Quality Council, as it relates to unit visits by commissioners, and the recruiting and training of more commissioners
- Rechartering percentage of units to date, by council and area
- Retention percentage of youth and units, by council and area
- Current ratio of units to registered unit commissioners, by council

## **CHAPTER 42. NATIONAL COMMISSIONER SUPPORT TEAM**

The national commissioner has a support team to help with specific duties. These national positions include:

- National commissioner service support chair
- National commissioner service training chair
- National commissioner service resources chair
- National commissioner service recruitment and retention chair

# **Background Information**



## **CHAPTER 43. A DETAILED HISTORY OF COMMISSIONER SERVICE IN SCOUTING**

The word “commission” dates back to 1344, when it was derived from the Latin word *commissionem*, meaning “delegation of business.” The nation’s monarch delegated authority to a deserving few.

Individuals identified by the monarch had to qualify as a “gentleman,” legally defined as a man who earned his income from property and as such was independently wealthy with time to devote to other agendas. It was exactly this kind of man that Lord Baden-Powell wanted as his volunteer commissioners: men of both money and leisure.

Baden-Powell’s first chief Scout commissioner was Lieutenant General Sir Edmond Roche Elles. Baden-Powell’s commissioners included W. F. deBois MacLaren, who donated Gilwell Park; and Rudyard Kipling, author of *The Jungle Book*.

As communities formed more troops, it became evident that leadership was needed to maintain standards, provide camping opportunities, recruit leaders, give training, establish local courts of honor, and stimulate local Scouting. This person was the commissioner.

The Scout commissioner represented the local community committee or council. A great deal of importance was placed upon the selection of this man. He was expected to have a great deal of outdoor experience and act as the local authority in all Scoutcraft matters.

While originally a volunteer, in some areas the community was able to raise enough funds for the Scout commissioner to become a salaried position.

The areas with paid leadership positions, such as a Scout executive or executive secretary, became known as first-class councils, while those with a volunteer head, still called the Scout commissioner, were known as second-class councils. By 1931, there was only one second-class council left.

The wreath of service that surrounds all commissioner and professional position badges is a symbol of the service rendered to units. It also symbolizes the continued partnership between volunteers and professionals.

Chief Scout Executive James West, at the first National Conference of Scout Executives in 1920, suggested that the Scout executive should be the general in the background, with the Scout commissioner as the ranking uniformed officer giving leadership to the Scoutmasters and acting as the ranking officer in public appearances.

West recognized that Scout executives would move around, and that the council would benefit from finding and developing a good Scout commissioner.

Volunteer national field commissioners were available as early as 1910 to help communities organize their local council and troops. There were 68 volunteer national field commissioners in 1913. Many of the volunteer national field commissioners worked for other agencies and traveled extensively, helping with Scouting wherever they went. Besides organizing new councils, they had to spend time correcting false starts and restraining those that wanted to implement their own brand of Scouting.

District commissioners were introduced in 1931 as an outgrowth of the deputy Scout commissioner position.

In the 1930s, local field commissioners were specialized representatives of the council and served a functional responsibility such as Cubbing, senior Scouting, Catholic Scouting, camping, emergency service corps, or Sea Scouts. They were on call to the district or neighborhood commissioners as technical experts of the program. Later, Exploring posts created commissioner positions known as the service team.

The growth of Scouting soon overloaded the district commissioner and his deputy, making it necessary to add commissioners to serve specific packs, ships, crews, and troops.

Scouting in the '30s was very community-focused, so the neighborhood commissioner position was developed to serve up to four units in the immediate local area.

In the 1950s and 1960s, the Scout commissioner was renamed the council commissioner. In many councils, this evolved into a ceremonial position with few or no duties. The district commissioner had reporting responsibilities to the Scout executive.

The 1970s were a decade for substantial growth in commissioner service. The neighborhood commissioner evolved into the unit commissioner, and the mission of the commissioner quickly became clear: Help units succeed. District commissioners were expected to hold a monthly meeting of the district Scouters roundtable. Eventually, this became too much for the district commissioner to handle, and the roundtable commissioner became an official position. In 1973, women were allowed to become Cub Scout unit commissioners or Cub Scout roundtable commissioners, and just a few years later, women were allowed to hold any commissioner position.

The first College of Commissioner Science was held in Atlanta, Georgia, in 1976. Courses included physical education, staging roll call and inspections, and exciting charter presentation ceremonies.

Beginning in 1999, there has been renewed emphasis on the role of the commissioner. Council commissioners are now accountable for the unit service program. The appointment of area and regional commissioners, as well as the creation of a national commissioner service support group, shows that at all levels of the organization, the importance of commissioner service is being recognized and emphasized.

Throughout the years, the commissioner service has been the one unifying factor that has made Scouting permanent. The commissioner has remained the line of service from council to unit to chartered organization.

National commissioners:

2008–present Tico Perez

2004–2008 Donald D. Belcher

1999–2004 William F. “Rick” Cronk

1990–1995 Earl G. Graves

1943–1960 George J. Fisher

1910–1941 Daniel Carter Beard

1910–1911 Peter S. Bomus

1910–1911 William Verbeck

From *A History of Commissioner Service in Scouting* by Randy Worcester.  
(randywoo@aol.com)

Middle Tennessee Council, Clarksville, Tennessee

Copyright 2009

## CHAPTER 44. VOLUNTARISM AND COMMISSIONERS

Time is precious, yet many adults in the United States give up some time to volunteer. No other country in the world depends so heavily upon volunteer efforts, and in no other country have citizens accepted so universally the idea that volunteer service is a requirement of good citizenship. Since most Americans accept this principle, and since there is no shortage of good causes to serve, each citizen can decide whether they volunteer and where.

Scouting exists and thrives because of its volunteers. So why should you choose to volunteer with Scouting? Perhaps these questions will help you decide.

Do you want to make a difference in the lives of others? Most of us do. Scouting's volunteers believe they are making a significant difference in the lives of youth.

Do you care about children and young people? If you do care, Scouting is for you.

Do you care about the future? It isn't always easy to care about it. Most of us are busy enough with today's problems. But if you care about the future of your country and its children, then you may find volunteer service in Scouting very satisfying. One of the best ways to help shape the future is to help young people who will ultimately own it and run it.

Do you care about the principles of the Boy Scouts of America? If you believe they are worth strengthening and spreading, then Scouting is a cause worth your gift of time.

Would you like your volunteer service to be different from your everyday work? Scouting is different, and you might find that refreshing. The skills you use in your job may be helpful to your volunteer service, but it won't be more of the same.

Do you enjoy relationships with spirited people? Scouting volunteers all serve a common cause, and it shows in our relationships with each other. We know why we are here, and we are enthusiastic about what we are doing.

One of the great ways to serve youth through Scouting is to be a commissioner, at any level.

## CHAPTER 45. MOVEMENTS VERSUS ORGANIZATIONS

It requires dozens of pages with small print to list the names of all the not-for-profit organizations in the United States. There are thousands of them. The Boy Scouts of America, however, is a movement, not an organization. There is an important difference.

The American Heritage Dictionary defines organization as "something that has been organized or made into an ordered whole; comprising elements with varied functions." There's nothing wrong with that. The definition can be applied to Scouting, too. But if thousands of volunteers are going to give their time to serve youth through Scouting, there ought to be something more than that.

The same dictionary describes a movement as the "activities of a group of people to achieve a specific goal." A movement, like Scouting, puts the emphasis on people, action, and a specific goal.

So for Scouting, organization is something to use rather than something to be. We know sound organization is needed if the Scouting movement is to succeed, but the boxes and lines on our organizational charts are not the Scouting movement. They are only the way in which we sort out our varied functions.

When you serve as commissioner, you are part of a worldwide movement composed of people dedicated to a common goal and who use organization as a means, not an end.

## CHAPTER 46. RESOURCES

Perhaps no other organization in America has as many helps available for its leaders as Scouting. These resources take many shapes, ranging from single sheets to the *Boy Scout Handbook*. *Scouting's Library of Literature*, available online, lists most of them.

For commissioners, the following special items are available:

<b><i>A Handbook for District Operations</i></b> , No. 34739	Provides insight into every aspect of the four functions of a district and council, including job descriptions for all commissioners.
<b><i>Commissioner Fieldbook for Unit Service</i></b> , No. 33621	Invaluable to every commissioner.
<b><i>Commissioner Helps for Packs, Troops, and Crews</i></b> , No. 33618	Suggests specific unit commissioner actions to help units meet specific standards and program objectives.
<b><i>Commissioner Basic Training Manual</i></b> , No. 33613 (Section II of this manual)	Complete syllabus for those planning and instructing this course.
<b><i>Continuing Education for Commissioners</i></b> , No. 33615 (Section III of this manual)	Detailed planning guide for council commissioner conferences, including the College of Commissioner Science. This section contains course outlines for commissioner meetings and conferences.
<b><i>Scouting's Library of Literature</i></b> , No. 70-080 (available for download online)	The best source of information for most literature and publications of BSA.
<b><i>Unit Commissioner Worksheets:</i></b> packs, No. 34125C; troops, No. 34126A; crews, No. 33660B; (available for download on the commissioner website)	For use after visiting a unit.
<b><i>Cub Scout Roundtable Planning Guide</i></b> , No. 34239C	Contains roundtable outlines for each month of the program year.
<b><i>Cub Scout Roundtable Commissioner and Staff Basic Training Manual</i></b> , No. 33013 (available to download online on the commissioner website)	A one-day course best conducted on a council basis but also used by districts.
<b><i>Boy Scout Roundtable Planning Guide</i></b> , No. 34253	A workbook based on possible program features and special feature topics.
<b><i>Boy Scout Roundtable Commissioner Training</i></b> , No. 34256 (available to download from the commissioner website)	A four-hour course best conducted on a council basis.

<b>Venturing Program Forum Guide</b> , No. 34342	Contains program forum activities, games, program features, and “how to” topics.
<b>Selecting District People</b> , No. 34512A	A must for the important job of recruiting a full staff.
<b>Commissioner Volunteer Duties Cards</b> , No. 34265	Wallet-size description cards for all commissioner jobs.
<b>Unit Commissioner Program Notebook</b> , No. 331-013	A handy pocket calendar and commissioner resource guide provided annually by <i>Boys’ Life</i> magazine.
<b>The Commissioner newsletter</b> , No. 522-975	Distributed periodically during the year to council commissioners and Scout executives. Also available on the commissioner Web site to download by any commissioner.

The commissioner website at [www.scouting.org/commissioners](http://www.scouting.org/commissioners) includes a number of resources including past issues of *The Commissioner* newsletter, current podcasts, roundtable resources, and PowerPoint presentations of previous subjects of interest to all commissioners. Also note the select line of saleable items to increase commissioner identity. They may be ordered at your council Scout shop or by calling 800-323-0732.

Helpful DVDs available include:

- **Commissioner Annual Orientation** DVD, AV-04DVD03
- **Meetings of the District**, DVD, No. AV-06DVD07
- **Commissioner Service and District Operation Support** DVD, No. AV-06DVD08, with audiovisuals in support of commissioner service, including
  - **The District Nominating Committee**
  - **Unit Commissioner’s Orientation: Helping Units Succeed**
  - **Unit Problem-Solving for Commissioners**
  - **District Key 3 Orientation**
  - **Highlights of District Operations for the 21st Century: How Districts Operate**

## **CHAPTER 47 BSA RULES AND REGULATIONS, ARTICLE VIII, ADULT LEADERSHIP SECTION 3, PAGE 7**

### **Clause 2: Commissioned Leadership**

All individuals selected to serve as commissioners (including Venturing service team members) shall be recommended by the Scout executive and approved by the council executive board (with the exception of the council commissioner, who is an elected officer). They shall be issued commissions by the Boy Scouts of America on an annual basis.

### **Clause 4: Council Commissioner**

The council commissioner shall direct the extent and quality of commissioner service through monthly meetings with district commissioners and commissioner conferences.

The council commissioner has the responsibility at the council level to report to the council president and regularly interpret the commissioner function to the council executive board.

The council commissioner is responsible for the local council's commitment to on-time re-registration of units.

The council commissioner shall serve as an officer of the council and as a National Council representative.

### **Clause 5: Assistant Council Commissioners**

Each local council may have one or more assistant council commissioners.

These individuals are appointed by the council commissioner and assist, on direction, in the performance of the duties of that office.

### **Clause 6: District Commissioner**

A district commissioner is offered for approval and appointment by the district nominating committee.

The district commissioner shall, through a volunteer staff, be responsible for on-time charter renewals, unit service, and monthly roundtables in the district and give leadership to recruiting, training, and supervision of an effective staff.

The district commissioner serves on the council commissioner's staff, reports to the district chairman, and has an advisory relationship with the district operating committees.



COMMUNITY ALLIANCES  
BOY SCOUTS OF AMERICA®



BOY SCOUTS OF AMERICA  
1325 West Walnut Hill Lane  
P.O. Box 152079  
Irving, Texas 75015-2079  
<http://www.scouting.org>

522-015  
2010 Second Printing